



AR
AERRE
R E L A X

W W W . A E R R E D I V A N I . I T

**VIVEZ L'EXPÉRIENCE DU
GRAND CONFORT**

YOUR IDEAL PLACE FOR REST

M A D E I N I T A L Y



AR 
AERRE
R E L A X

Nos fauteuils relax . Our relax chairs



Agata - 41



Alma - 25



Ambra - 51



Angelica - 47



Arianna - 35



Bruna - 49



Carina - 23



Clara - 27



Cora - 53



Giada - 37



Gioia - 43



Grazia - 45



Ines - 19



Irene - 31



Linda - 21



Mara - 29



Regina - 33



Serena - 39

Structure du fauteuil RELAX RELAX armchair structure

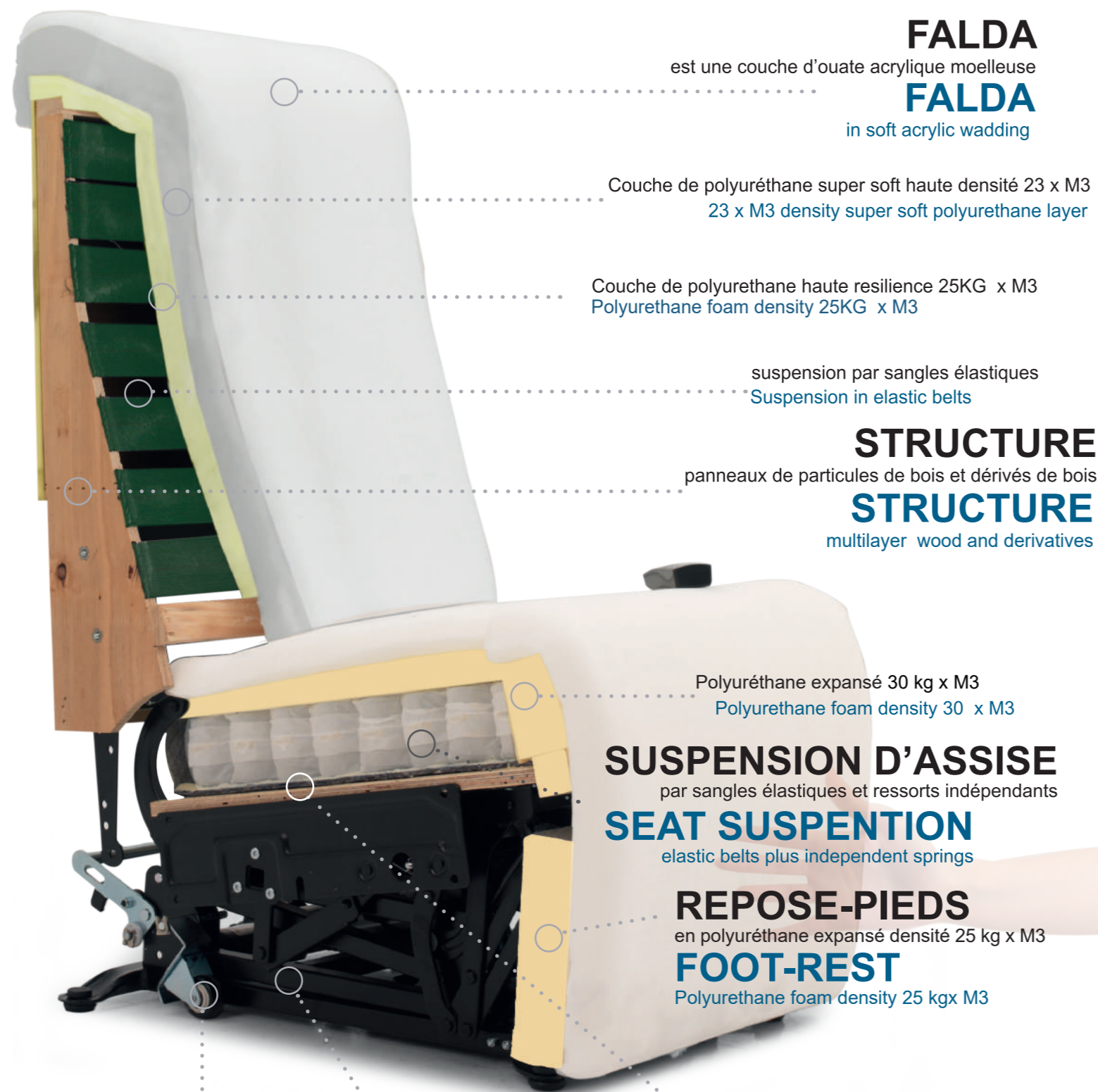

FALDA

est une couche d'ouate acrylique moelleuse

FALDA

in soft acrylic wadding

Couche de polyuréthane super soft haute densité 23 x M3
23 x M3 density super soft polyurethane layer

Couche de polyuréthane haute resiliance 25KG x M3
Polyurethane foam density 25KG x M3

suspension par sangles élastiques
Suspension in elastic belts

STRUCTURE

panneaux de particules de bois et dérivés de bois

STRUCTURE

multilayer wood and derivatives

Polyuréthane expansé 30 kg x M3
Polyurethane foam density 30 x M3

SUSPENSION D'ASSISE

par sangles élastiques et ressorts indépendants

SEAT SUSPENTION

elastic belts plus independent springs

REPOSE-PIEDS

en polyuréthane expansé densité 25 kg x M3

FOOT-REST

Polyurethane foam density 25 kgx M3

FEUTRE

à haute résistance

FEUTRE

High resistance

SYSTÈME ROLLER

roulettes rétractables par simple pédale de déclenchement

ROLLER SYSTEM

Extractable wheels with special release pedal

MECANISME

double moteur électrique avec releveur

MECHANISM

double electric motor with lift

Le siège innovant AIR-System est un système qui crée une circulation d'air à son intérieur lors de sa normale utilisation, en compression et décompression, grâce aux ressorts en acier (photo A) recouverts de tissu et aux fentes latérales (photo B) ; ce système offre une nombre d'avantages très importants

- Réduction de la formation d'acariens.
- Réduction de la formation de moisissures.
- Réduction de la formation d'humidité et de condensation.
- Réduction du chauffage des sièges.

AIR-System Le siège qui Respire The breathing seat



Photo A

AIR-System est une NOUVEAUTE exclusive de AERRE

The innovative AIR-System seat system creates an inside flow of air circulation during the normal use of compression and decompression thanks to the steel springs (photo A) covered with fabric and to the side slits (photo B). This system offers a number of very important advantages:

- Reduction of mite formation.
- Reduction of mould formation.
- Reduction of moisture and condensation formation.
- Reduction of seat heating.

AIR-System is an exclusive NEWS from AERRE

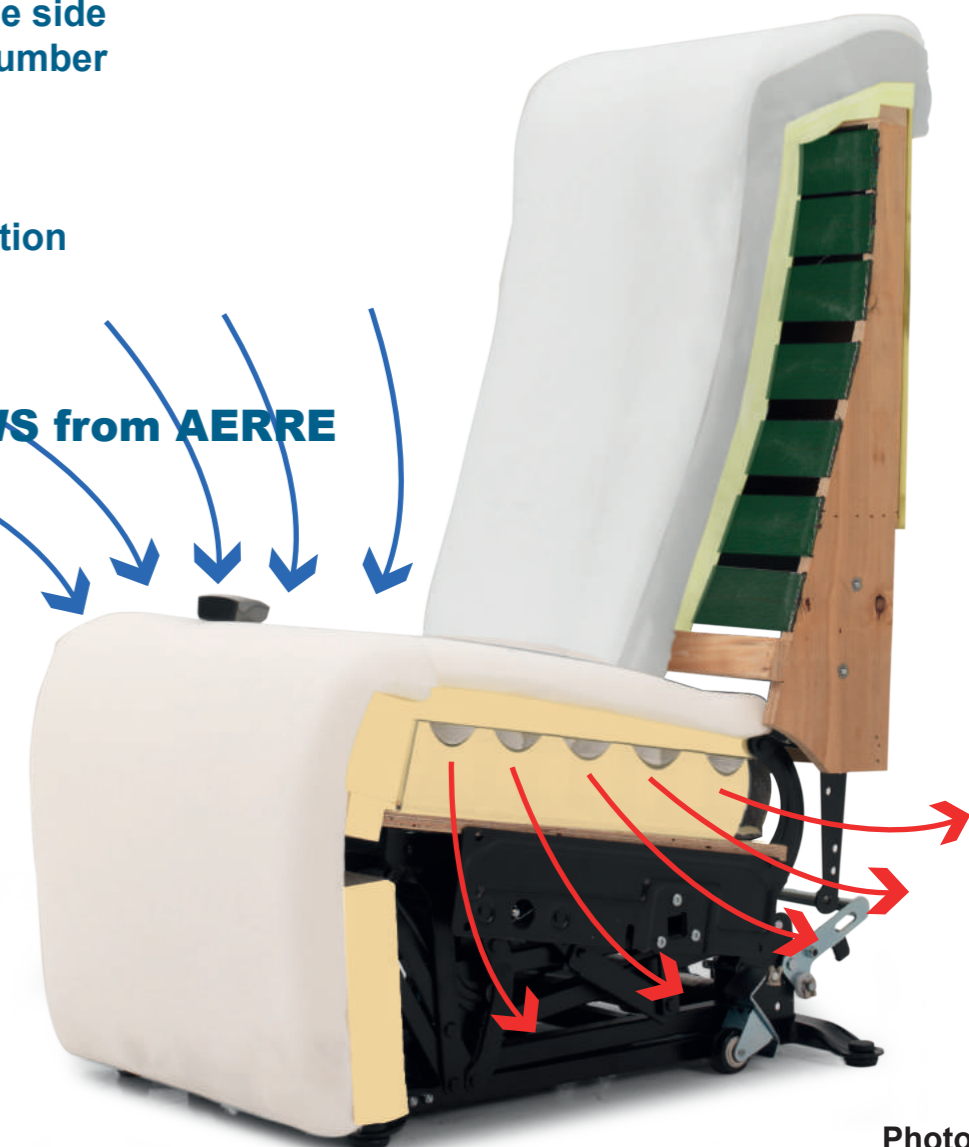

Photo B

MOUVEMENTS MOVEMENTS



La “**Position TV**” offre une confortable position d’assise avec la possibilité de régler (avant et arrière) le dossier et le repose-pieds, au centimètre près.

The “**TV Position**” offers a comfortable sitting position with the possibility to adjust (back and forth) the backrest and the footrest to the centimetre.



La “**Position Relaxation**” vous permet d’atteindre une position « lit » pour offrir un repos vraiment régénérant.

The “**Relaxation Position**” allows you to reach a bed position offering a truly regenerating rest.



La “**Position Releveur**” aide la personne à se lever.

The “**Lift Position**” facilitates the standing of the person, bringing it to reach the ideal position to get up.



Option. **VERSION S***
L’assise surbaissée” facilite l’utilisation dans de situations spécifiques.
Hauteur d’assise 43 cm **

Optional. **S VERSION***
The “lowered seat” facilitates use in specific situations.
Seat Height 43 cm **

*Version **S** disponible uniquement sur les fauteuils **ALMA, LINDA** et **MARA**.
Pour la **version S ne sont pas disponibles: l’assise **AIR-System** et Memory Foam, ma uniquement en mousse polyuréthane -densité de 30 kgm3.

* **S** version available only on **ALMA, LINDA** and **MARA** armchair.

The **S version does not provide the **AIR-System Seat** and Memory Foam Seat, but only polyurethane foam Seat density 30 kgm3.

VERSION M

fauteuil STANDARD conçu pour garantir un confort unique dans toutes les situations.

VERSION M

STANDARD armchair designed to guarantee an unique comfort in all situations



Option. VERSION XL*

Spécialement conçu pour les « grandes tailles » ; ce fauteuil est équipé d’un mécanisme renforcé capable de soulever jusqu’à 180 kg, avec une assise plus large de 12 cm par rapport aux fauteuils normaux.

Optional. XL VERSION*

Specifically designed for the plus sizes, this armchair is equipped with a reinforced mechanism able to lift up to 180 kg, with a seat increased by 12 cm in width compared to normal seats.

* Version **XL** disponible uniquement sur les fauteuils **AGATA, ALMA, LINDA** et **MARA**.

* **XL** Version available only on **AGATA, ALMA, LINDA** and **MARA** armchairs.

Standard. ZERO GRAVITY

Tous nos fauteuils sont étudiés et réalisés selon le principe dit “ZERO GRAVITY”, qui place les genoux au même niveau du cœur, et améliore la circulation sanguine, avec un important effet bénéfique.



All our armchairs are designed and built according to the so-called “ZERO GRAVITY” principle, which places the knees at the same level of the heart, improves and makes blood circulation more efficient, obtaining an important beneficial effect.

Standard. BRACCIOLI ESTRAIBILI (à baïonnette / by bayonets)

Le fauteuil est équipé d'accoudoirs extractibles (à baïonnette) qui vous permettent de le déplacer facilement d'une pièce à l'autre et surtout de déplacer la personne du fauteuil au lit ou de rapprocher le fauteuil de la table

The chair has removable side arms (by bayonets) - enables side transfers out of the chair with the minimum of difficulty. Left hand, right hand or both.



Standard. TENDINA

Le fauteuil est équipé d'un «petit rideau» qui cache le mécanisme.

The chair has a « little curtain » to hide the mechanism.



Standard. SCHIENALE REMOVIBILE

1



Facile à enlever et à insérer grâce au système « à baïonnette »
Easy to remove and to insert thanks to the bayonet system

2



Le “Schienale Removibile” réduit l'encombrement du fauteuil, facilitant son transport.

The “Schienale Removibile” reduces the footprint of the chair, easing transport.

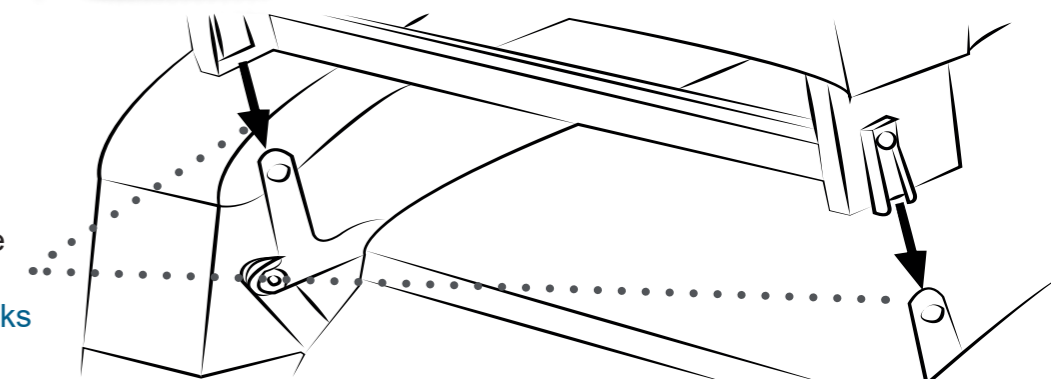

Optional. SET COPRIPOLTRONA



1

TRES FACILE À ENLEVER ET À LAVER
FAST TO REMOVE AND TO WASH

Le « **Set Copripoltrona** » a été conçu pour protéger le fauteuil de l'usure et empêcher de se salir. Disponible en plusieurs coloris, une solution excellente pour renouveler l'image de votre fauteuil ou donner une touche de couleur à votre pièce. Léger et élégant, il garantit une très bonne couverture du dos, du siège et des accoudoirs.

Il est disponible dans tous les tissus de la Cat. A (IDRO)

The « **Set Copripoltrona** » is designed to protect the chair from wear and to prevent it from getting dirty. Available in different colours, an excellent solution to renew the image of your armchair and give a touch of colour to the furniture. Light and elegant, it guarantees excellent coverage for the back, the seat and the armrests.

You can have it in all fabrics of Cat. A (IDRO)

2



Optional. TELECOMANDO WIRELESS



La « **Telecomando WIRELESS** » consente de faire bouger le fauteuil dans toutes les positions, à distance et pas liés au fil.

« **Telecomando WIRELESS** » allows to move the armchair in all positions without being tied to the wire.

Optional. VIBRO MASSAGGIO

Il est possible d'intégrer au fauteuil un système « **Vibro Massaggio** » qui agit sur le dos, les fesses et les jambes. Le massage est doux et léger, très utile pour stimuler le système cardiovasculaire et revitaliser le tonus musculaire. Il offre une agréable sensation de bien-être et permet d'atteindre un haut niveau de relaxation. Le mécanisme est composé de 6 dispositifs vibrants positionnés à l'arrière et à l'assise. Il est géré par une télécommande multifonction avec plusieurs types de programmation.



A « **Vibro Massaggio** » system that acts on the back, buttocks and legs can be integrated into the chair. The massage is gentle and light, very useful for stimulating the circulatory system and revitalizing muscle tone. It gives a pleasant feeling of well-being and allows reaching a high level of relaxation. The mechanism is composed of 6 vibrating devices positioned in the back and in the seat. It is managed by a multifunction remote control with different types of programming.

Optional. SEDUTA MEMORY FOAM



Grâce au 30 mm de « **Seduta MEMORY foam** », un spécial matériel en mousse viscoélastique qui compose sa structure moléculaire, cette assise s'adapte parfaitement aux formes anatomiques du corps ; en utilisant la chaleur corporelle assure un super confort, réduisant au minimum les points de pression et favorisant le flux normal de la circulation sanguine.

Thanks to 30 mm « **Seduta MEMORY foam** », a particular visco-elastic foam material that composes its special molecular structure, adapts perfectly to the anatomical shapes of the body, taking advantage of the body heat ensures maximum comfort, reducing to a minimum the pressure points and promoting the normal flow of blood circulation.

Optional. POGGIATESTA CERVICAL en Flocons de Polyester / in Polyester Staple



Le « **Poggiatesta Cervical** » est un coussin très confortable, à placer sur la partie supérieure du dossier, pour supporter une zone délicate, telle que celle cervicale.

The « **Poggiatesta Cervical** » is a comfortable cushion to be placed in the upper part of the back, to support a delicate area, such as the cervical one.



Optional. BATTERIA



La “**Batteria Ricaricabile al Litio**” permet l’alimentation du fauteuil même en absence d’un câble électrique. Avec ce système il est possible faire bouger le fauteuil en totale liberté. Durée de vie : pour une personne de 80 kg, près 100 mouvements.

“**Batteria Ricaricabile al Litio**” allows the chair to be recharged even if there is no electrical outlet, so that it is possible to move the armchair in total freedom. Duration: for a person of 80kg about 100 movements.

Optional. TAVOLINO

“**Tavolino**” est une excellent plan d’appuis pour lire, manger et travailler à l’ordinateur

“**Tavolino**” is an excellent shelf for reading, eating and working at the computer while sitting.



Accoudoirs et Tête removibles permettent un passage facile du fauteuil à un autre siège ou au lit.

Removable *Armrest and Headrest* allow easy passage from the armchair to another seat or to the bed.



Optional. ROLLER SYSTEM



Le “**Roller System**” permet de déplacer le fauteuil, même avec une personne dessus, grâce à un système de 4 roulettes rétractables Avec une simple pression sur le spécial levier métallique, les roulettes sont activées (voir photo), ce qui permet au fauteuil de bouger.

The “**Roller System**” allows the movement of the armchair, even with the person seated on it through a system of 4 removable wheels. By simply pressing the appropriate metallic lever, the wheels are activated (see photo) which allows the chair to move.

Optional. VERTICAL SYSTEM

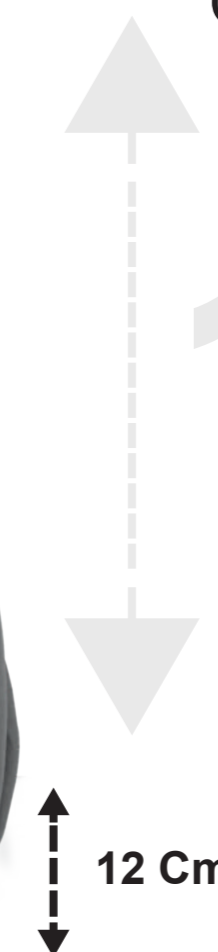

12 Cm

Le “**Vertical System**” est un système qui aide le fauteuil à se lever verticalement d’environ 12 cm avant de terminer la course en position LIFT. Cela permet à la personne qui l’utilise de s’approcher de la table pour manger ou travailler confortablement.

The “**Vertical System**” helps the chair to rise vertically by about 12 cm before finishing the run in the LIFT position. Thus allowing the person who uses it to approach the table to eat or work in comfort.



SEMI

DIMENSIONS - SIZES

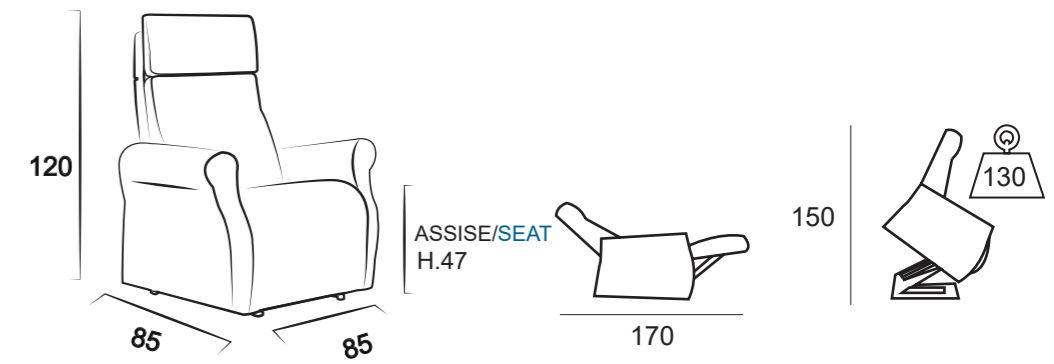

OPTIONAL



Tête Réglable
Différentes 3 positions pour garantir un confort unique et régler l'inclinaison de la tête.

Reclining Headrest
3 different positions for an extra confort and an head inclination adjustment.

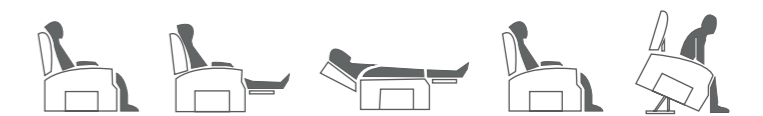

OPTIONAL **Linda - S**



Hauteur assise 43 Cm
Seat height 43Cm

OPTIONAL **Linda - XL**



LINDA

DIMENSIONS - SIZES

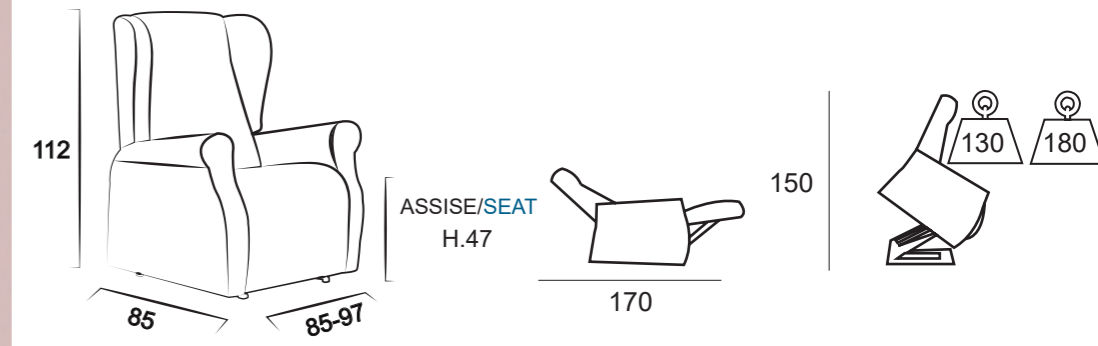

OPTIONAL

SET COPRIPOLTRONA	TELECOMANDO WIRELESS	BATTERIA	KIT VIBRO	KIT ROLLER -pas pour la version XL- -not for the version XL-
VERTICAL SYSTEM	SEDUTA MEMORY FOAM	VERSIONE S	VERSIONE XL	POGGIATESTA





CARINA

DIMENSIONS - SIZES

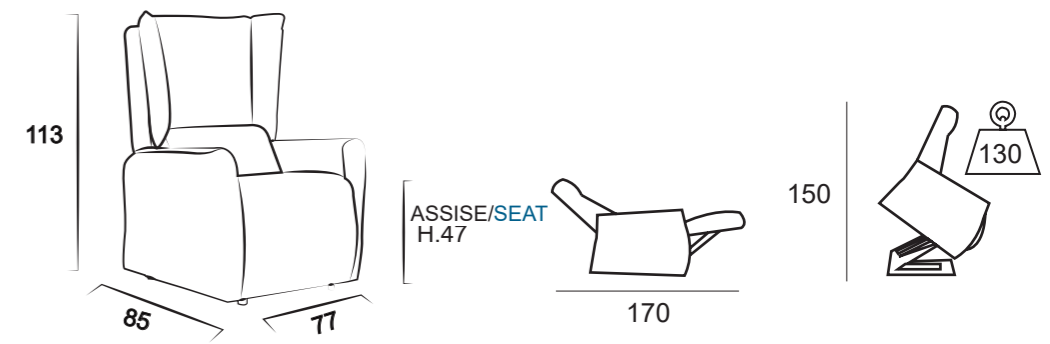

OPTIONAL



OPTIONAL **Linda - S**



Hauteur assise 43 Cm
Seat height 43Cm

OPTIONAL **Alma - XL**



ALMA

DIMENSIONS - SIZE

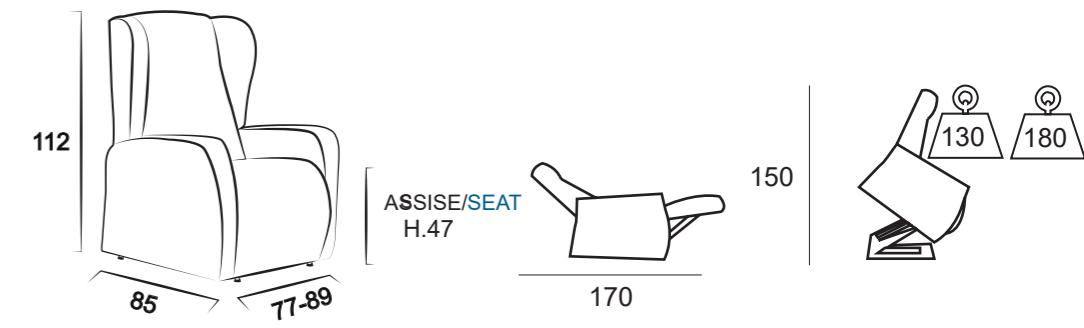

OPTIONAL

 SET COPRIPOLTRONA	 TELECOMANDO WIRELESS	 BATTERIA	 KIT VIBRO	 KIT ROLLER <small>-pas pour la version XL- -not for the version XL-</small>
 VERTICAL SYSTEM	 SEDUTA MEMORY FOAM	 VERSIONE S	 VERSIONE XL	 POGGIATESTA





CELARA

DIMENSIONS - SIZES

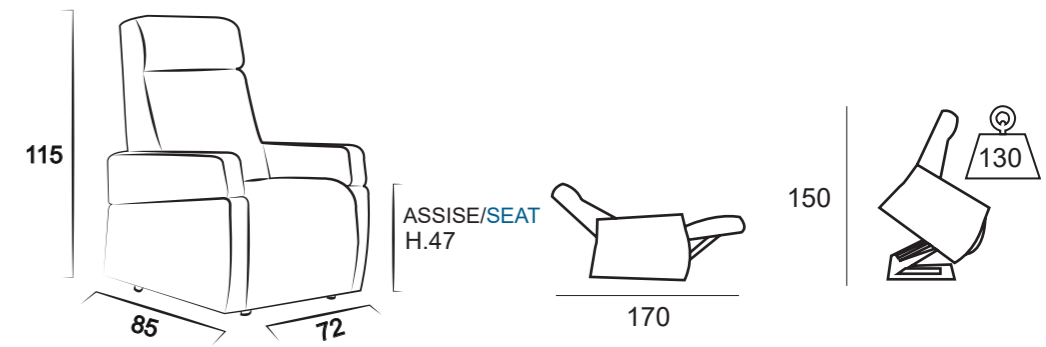

OPTIONAL

SET COPRIPOLOTRONA	TELECOMANDO WIRELESS	BATTERIA	KIT VIBRO	KIT ROLLER
VERTICAL SYSTEM	SEDUTA MEMORY FOAM	POGGIATESTA	TAVOLINO	

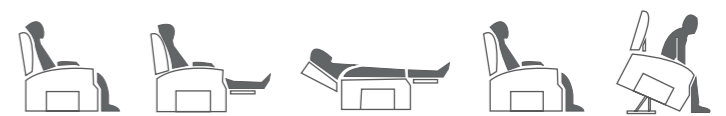

OPTIONAL **Linda - S**



Hauteur assise 43 Cm
Seat height 43Cm

OPTIONAL **Mara - XL**



MARA



DIMENSIONS - SIZES

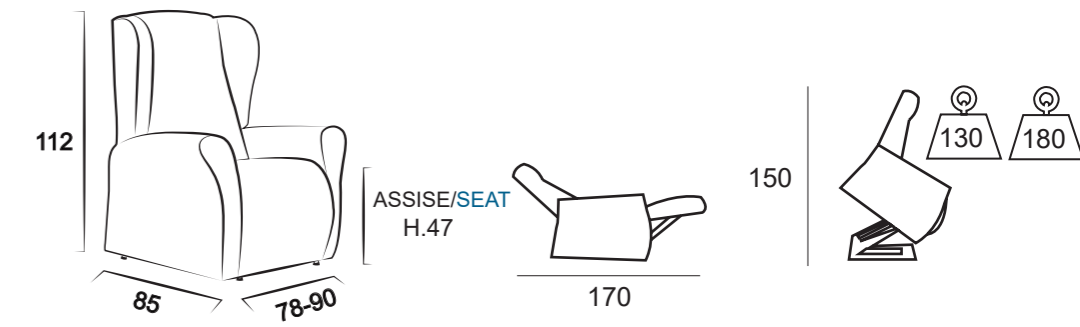

OPTIONAL

 SET COPRIPOLTRONA	 TELECOMANDO WIRELESS	 BATTERIA	 KIT VIBRO	 KIT ROLLER <small>-pas pour la version XL- -not for the version XL-</small>
 VERTICAL SYSTEM	 SEDUTA MEMORY FOAM	 VERSIONE S	 VERSIONE XL	 POGGIATESTA



IRENE



DIMENSIONS - SIZES

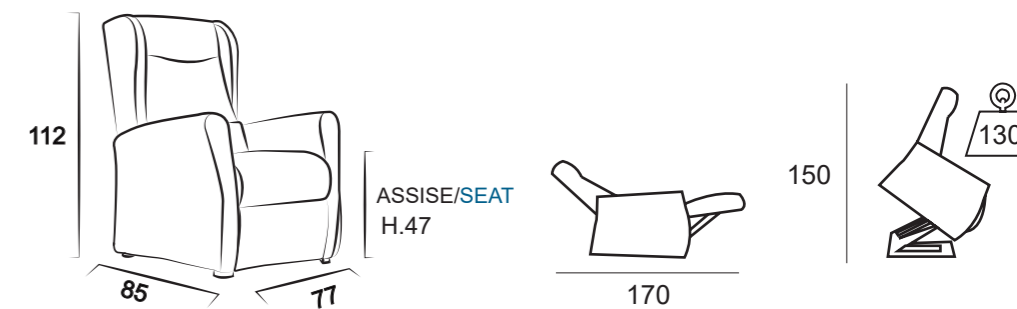

OPTIONAL



SET
COPRIPOLTRONA



TELECOMANDO
WIRELESS



BATTERIA



KIT
VIBRO



KIT
ROLLER



VERTICAL
SYSTEM



SEDUTA
MEMORY FOAM



POGGIATESTA





REGINA

DIMENSIONS - SIZES

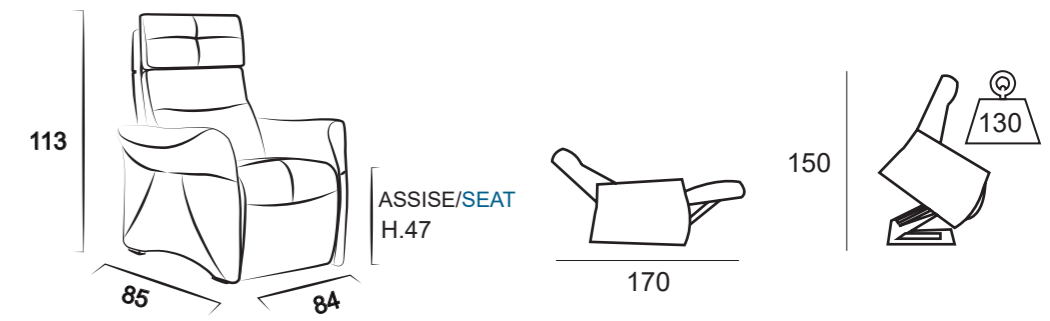

OPTIONAL

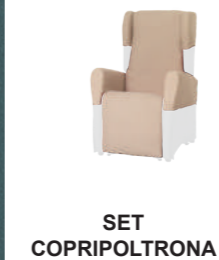

Tête Reglable
Différentes 3 positions pour garantir un confort unique et régler l'inclinaison de la tête.

Reclining Headrest
3 different positions for an extra confort and an head inclination adjustment.





ARRIVIA

DIMENSIONS - SIZES

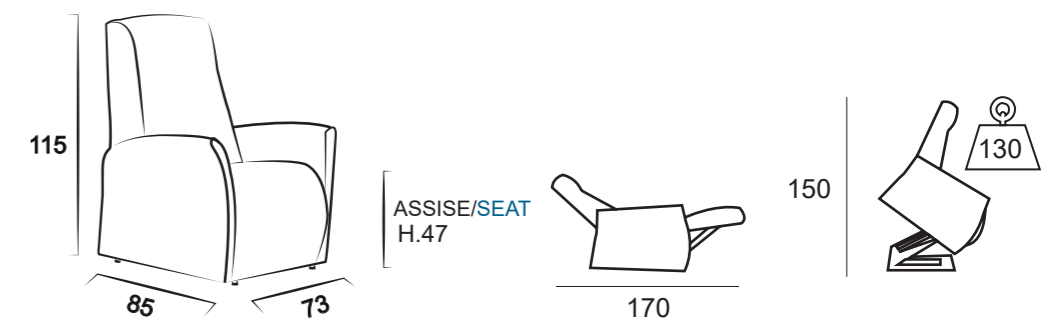

OPTIONAL

 SET COPRIPOLTRONA	 TELECOMANDO WIRELESS	 BATTERIA	 KIT VIBRO	 KIT ROLLER
 VERTICAL SYSTEM	 SEDUTA MEMORY FOAM	 POGGIATESTA		



GIADA



DIMENSIONS - SIZES

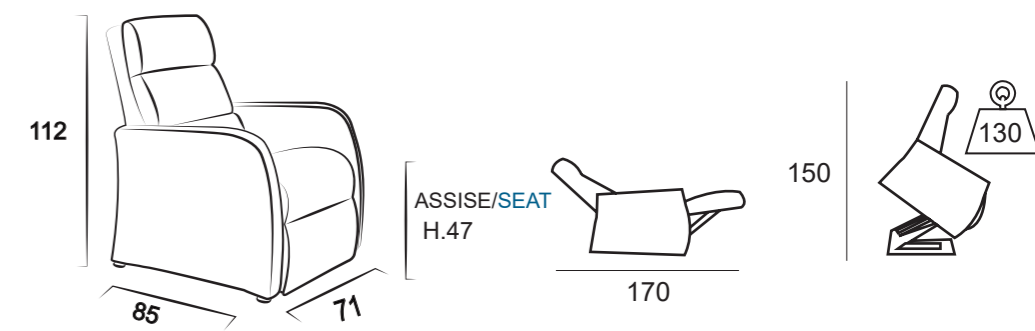

OPTIONAL

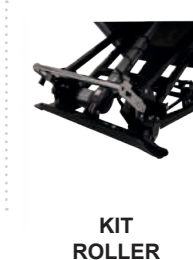



SERENA

DIMENSIONS - SIZES

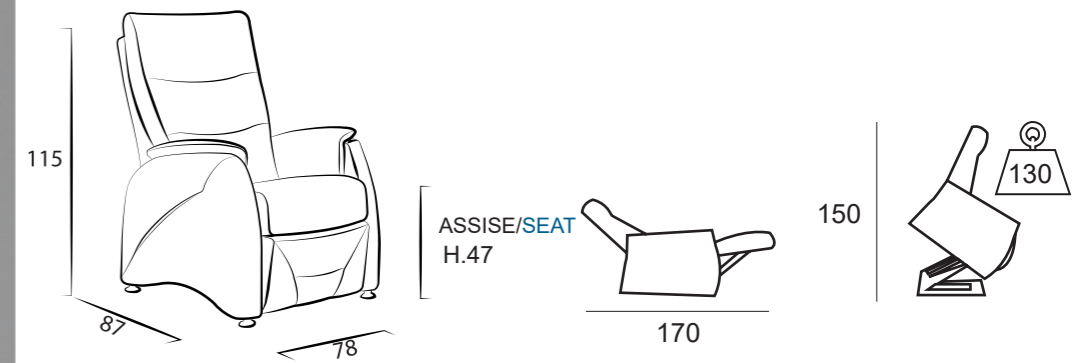

OPTIONAL

				
SET COPRIPOLTRONA	TELECOMANDO WIRELESS	BATTERIA	KIT VIBRO	KIT ROLLER
				
VERTICAL SYSTEM	SEDUTA MEMORY FOAM	POGGIATESTA		



OPTIONAL Agata - XL



AGATA



DIMENSIONS - SIZES

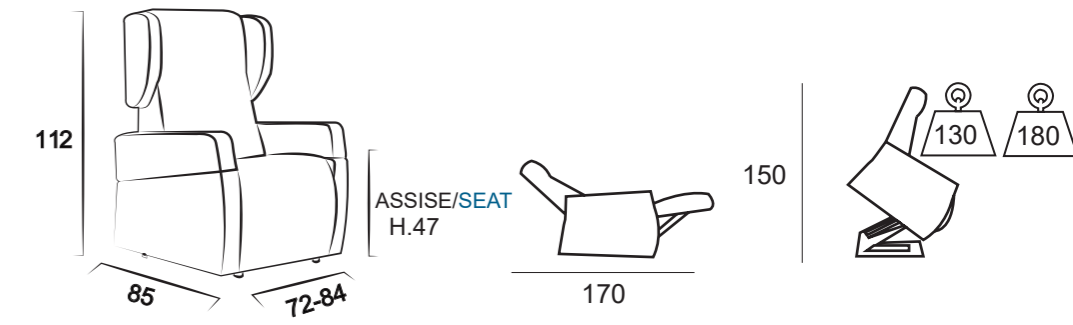

OPTIONAL





GLORIA

DIMENSIONS - SIZES

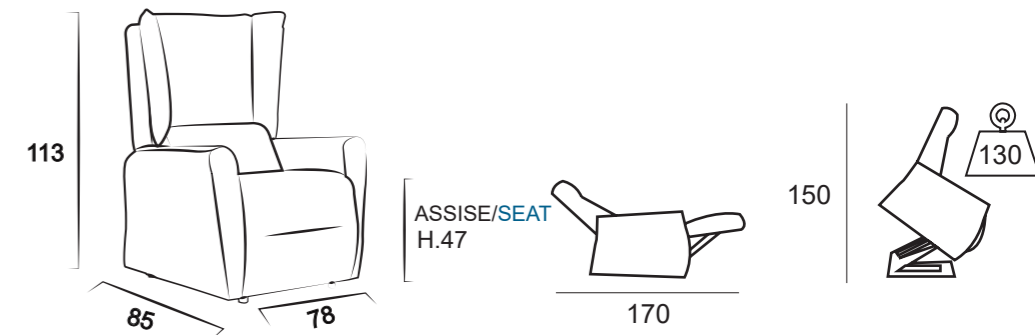

OPTIONAL

 SET COPROPOLTRONA	 TELECOMANDO WIRELESS	 BATTERIA	 KIT VIBRO	 KIT ROLLER
 VERTICAL SYSTEM	 SEDUTA MEMORY FOAM	 POGGIATESTA		





GRAZIA

DIMENSIONS - SIZES

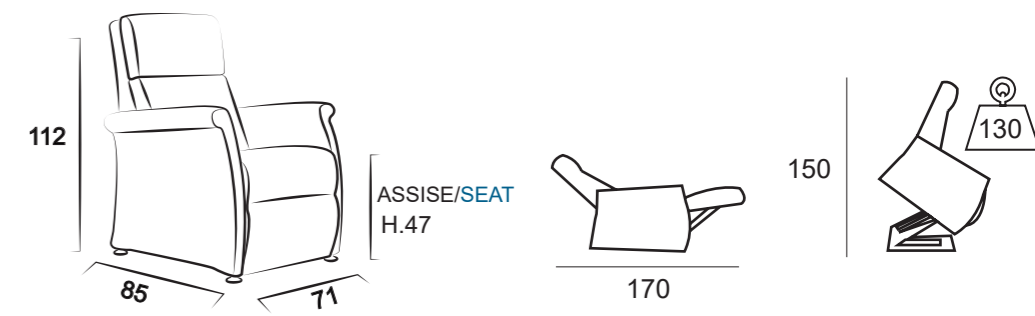

OPTIONAL

SET COPRIPOLTRONA	TELECOMANDO WIRELESS	BATTERIA	KIT VIBRO	KIT ROLLER
VERTICAL SYSTEM	SEDUTA MEMORY FOAM	POGGIATESTA		



VIRGINIA



DIMENSIONS - SIZES

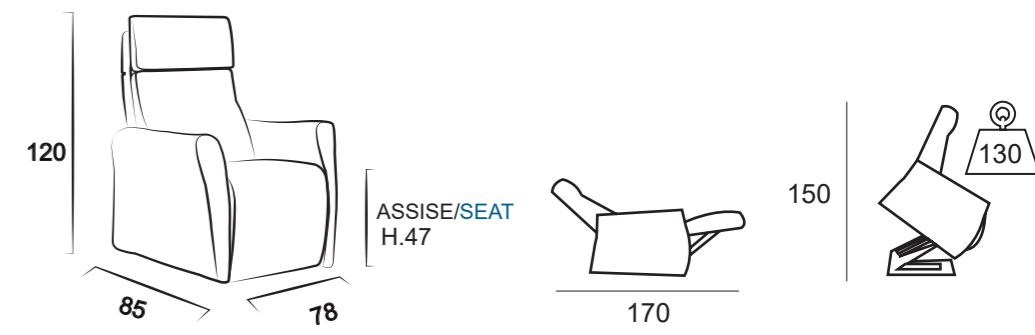

OPTIONAL

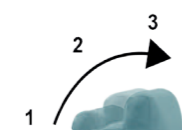
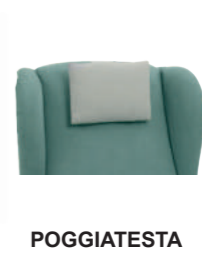
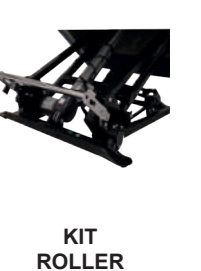

Tête Reglable
Différentes 3 positions pour garantir un confort unique et régler l'inclinaison de la tête.

Reclining Headrest
3 different positions for an extra confort and an head inclination adjustment.

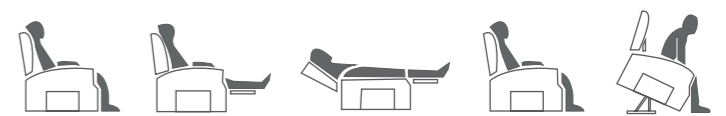

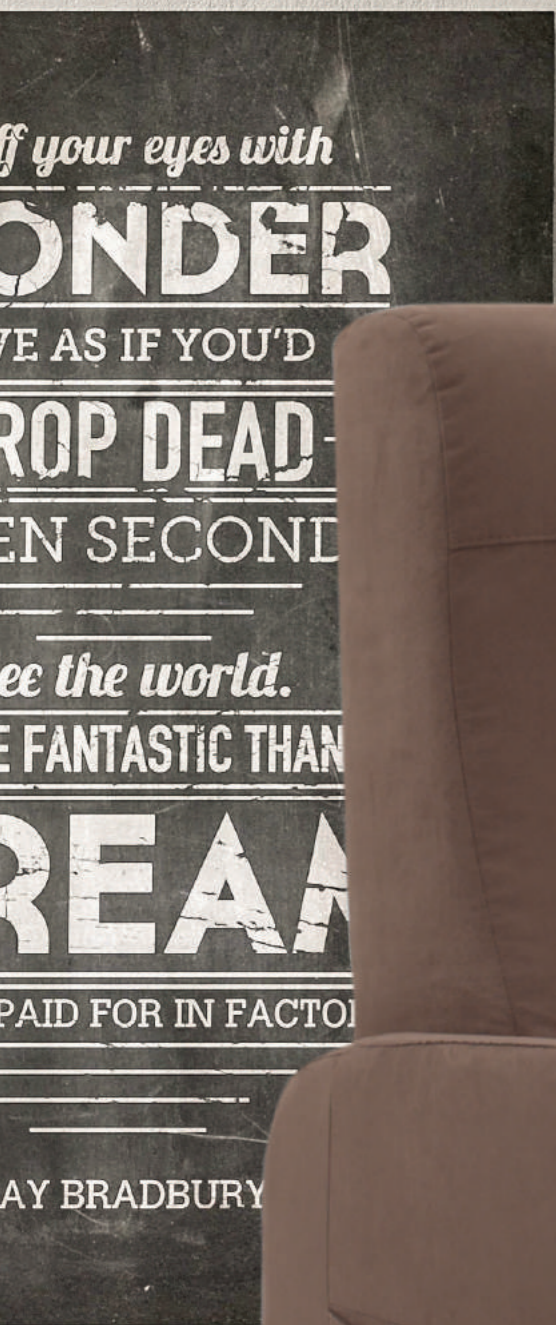

VANNER

DIMENSIONS - SIZES

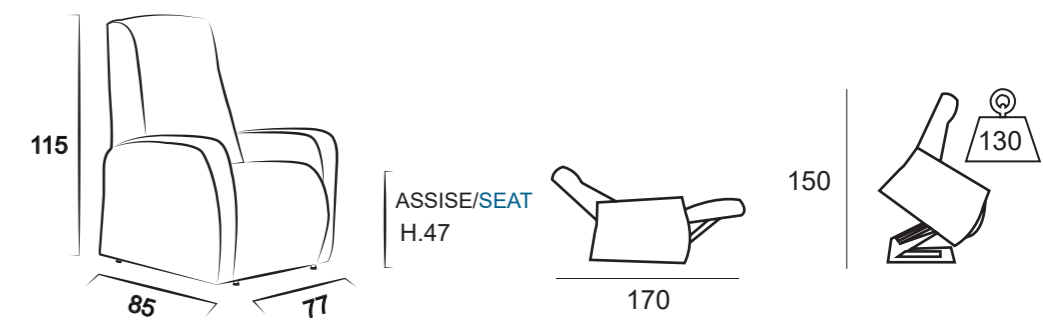

OPTIONAL



SET COPRIPOLTRONA



TELECOMANDO WIRELESS



BATTERIA



KIT VIBRO



KIT ROLLER



VERTICAL SYSTEM



SEDUTA MEMORY FOAM



POGGIATESTA





VERENA

DIMENSIONS - SIZES

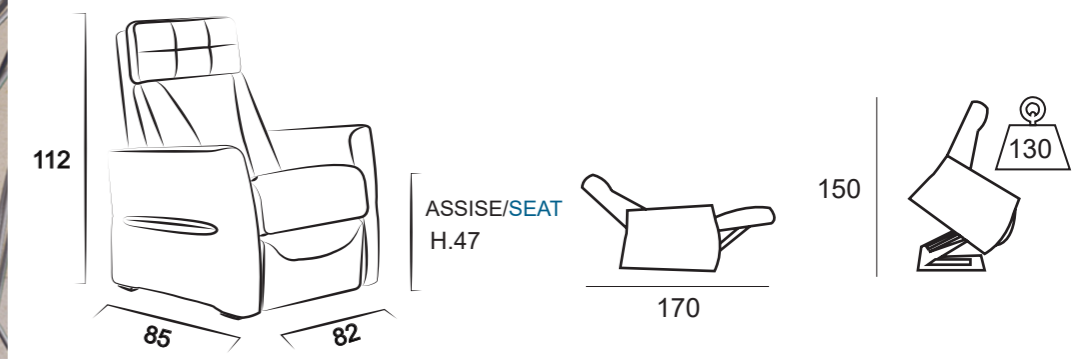

OPTIONAL

 SET COPRIPOLTRONA	 TELECOMANDO WIRELESS	 BATTERIA	 KIT VIBRO	 KIT ROLLER
 VERTICAL SYSTEM	 SEDUTA MEMORY FOAM	 POGGIATESTA		

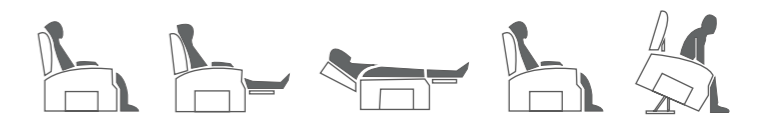

CORA



DIMENSIONS - SIZES

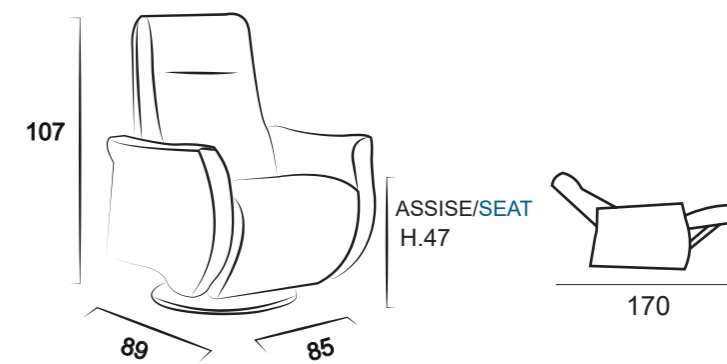

OPTIONAL



SET
COPRIPOLTRONA



TELECOMANDO
WIRELESS



BATTERIA



KIT
VIBRO



SEDUTA
MEMORY FOAM



POGGIATESTA



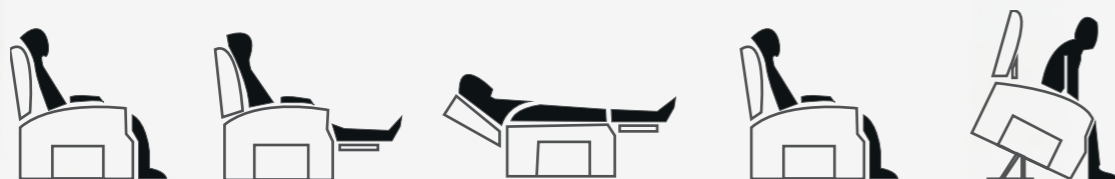

STRUCTURE

Sapin peuplier,
multiplis et panneaux de
particules

GARNISSAGE

Mousse polyuréthane expansé
haute résilience

Assises:

Ressorts ensachés densité 30
kg x m³ +

couche acrylique

Dossier:

densité 21 kg x m³

SUSPENSION D'ASSISE

Sangles élastiques haute
résistance

RETEMENT

Tissu:

partiellement déhoussable

PVC:

partiellement déhoussable

STRUCTURE

Framework in poplar,
fir and various derivatives

UPHOLSTERY

Polyurethane foam-various
densities +

acrylic wadding

Seats:

pocket springs + foam density

30 kg x m³

Backrest:

density 21 kg x m³

SEAT SUPPORT

High strength elastic straps

COVERING

Fabric:

partially removable

Artificial leather:

partially removable

AR
AERRE
D I V A N I

FLAG srl

Sede Legale: VIA G.GALILEI, 11/4

Sede Amm. ed Operativa: VIA MIMOSE, 42

51039 QUARRATA (PT)

TEL. + 39 0573 79710 FAX + 39 0573 734370 / +39 0573 797175

INFO@AERREDIVANI.IT - WWW.AERREDIVANI.IT

FLAG se réserve le droit de modifier sans préavis les matériaux, les revêtements, les finitions et les produits présentés dans ce catalogue. Les couleurs des matériaux et des finitions sont indicatives car elles sont soumises aux tolérances des processus d'impression.

FLAG reserves the right to make changes in the materials, coatings, finishes and products presented in this catalogue without prior notice. The colours of the materials and finishes are indicative as they are subject to the tolerances of the printing processes.



AR
AERRE
R E L A X



AR
AERRE
R E L A X

